

Keysight N7020A Power Rail Probe

User's Guide



Notices

© Keysight Technologies 2014, 2015

No part of this manual may be reproduced in any form or by any means (including electronic storage and retrieval or translation into a foreign language) without prior agreement and written consent from Keysight Technologies, Inc. as governed by United States and international copyright laws.

Manual Part Number

N7020-97002

Edition

Third edition, October 2015

Published by:

Keysight Technologies
1400 Fountaingrove Parkway
Santa Rosa, CA, 95403

Warranty

The material contained in this document is provided "as is," and is subject to being changed, without notice, in future editions. Further, to the maximum extent permitted by applicable law, Keysight disclaims all warranties, either express or implied, with regard to this manual and any information contained herein, including but not limited to the implied warranties of merchantability and fitness for a particular purpose. Keysight shall not be liable for errors or for incidental or consequential damages in connection with the furnishing, use, or performance of this document or of any information contained herein. Should Keysight and the user have a separate written agreement with warranty terms covering the material in this document that conflict with these terms, the warranty terms in the separate agreement shall control.

Technology Licenses

The hardware and/or software described in this document are furnished under a license and may be used or copied only in accordance with the terms of such license.

U.S. Government Rights

The Software is "commercial computer software," as defined by Federal Acquisition Regulation ("FAR") 2.101. Pursuant to FAR 12.212 and 27.405-3 and Department of Defense FAR Supplement ("DFARS") 227.7202, the U.S. government acquires commercial computer software under the same terms by which the software is customarily provided to the public. Accordingly, Keysight provides the Software to U.S. government customers under its standard commercial license, which is embodied in its End User License Agreement (EULA), a copy of which can be found at <http://www.keysight.com/find/sweula>. The license set forth in the EULA represents the exclusive authority by which the U.S. government may use, modify, distribute, or disclose the Software. The EULA and the license set forth therein, does not require or permit, among other things, that Keysight: (1) Furnish technical information related to commercial computer software or commercial computer software documentation that is not customarily provided to the public; or (2) Relinquish to, or otherwise provide, the government rights in excess of these rights customarily provided to the public to use, modify, reproduce, release, perform, display, or disclose commercial computer software or commercial computer software documentation. No additional government requirements beyond those set forth in the EULA shall apply, except to the extent that those terms, rights, or licenses are explicitly required from all providers of commercial computer software pursuant to the FAR and the DFARS and are set forth specifically in writing elsewhere in the EULA. Keysight shall be under no obligation to update, revise or otherwise modify the Software. With respect

to any technical data as defined by FAR 2.101, pursuant to FAR 12.211 and 27.404.2 and DFARS 227.7102, the U.S. government acquires no greater than Limited Rights as defined in FAR 27.401 or DFAR 227.7103-5 (c), as applicable in any technical data. 52.227-14 (June 1987) or DFAR 252.227-7015 (b)(2) (November 1995), as applicable in any technical data.

Safety Notices

CAUTION

A **CAUTION** notice denotes a hazard. It calls attention to an operating procedure, practice, or the like that, if not correctly performed or adhered to, could result in damage to the product or loss of important data. Do not proceed beyond a **CAUTION** notice until the indicated conditions are fully understood and met.

WARNING

A **WARNING** notice denotes a hazard. It calls attention to an operating procedure, practice, or the like that, if not correctly performed or adhered to, could result in personal injury or death. Do not proceed beyond a **WARNING** notice until the indicated conditions are fully understood and met.

Contents

- 1 General Information / 5**
 - Oscilloscope Compatibility / 7
 - Accessories / 8
 - Inspecting the Probe / 15
 - Handling the Probe / 16
 - Cleaning the Probe / 17
 - Safety Information / 18
 - Returning the Probe for Service / 20
 - Contacting Keysight Technologies / 21

- 2 Using the N7020A / 23**
 - Requirements for Optimum Probe Performance / 24
 - Common Types of Power Integrity Measurements / 27
 - Connecting to the DUT / 29
 - Avoiding Costly Repairs / 31

- 3 Calibrating / 33**
 - DC Attenuation/Offset Calibration Using N7022A Main Cable / 34
 - DC Attenuation/Offset Calibration Using N7023A Power Rail Probe Browser / 35
 - Skew Calibration (Optional) / 36

- 4 Specifications and Characteristics / 41**
 - Specifications and Characteristics / 42
 - Probe Dimensions / 44

- 5 Performance Plots / 45**
 - N7020A Performance Plots / 46

Contents

N7020A Input Impedance Equivalent Model / 50

6 Performance Verification / 53

Procedure / 54

Performance Test Record / 55

Index

1 General Information

Oscilloscope Compatibility	7
Accessories	8
Inspecting the Probe	15
Handling the Probe	16
Cleaning the Probe	17
Safety Information	18
Returning the Probe for Service	20
Contacting Keysight Technologies	21

The N7020A power-rail probe is designed for power integrity measurements such as Periodic and Random Disturbances (PARD), static and dynamic load response, and programmable power-rail response. The N7020A provides the following advantages:

- Low noise due to a low attenuation ratio (1.1:1) and 50 Ω output. See [Figure 1](#) on page 6 and [Figure 2](#) on page 6.
- A large $\pm 24\text{V}$ probe offset range. The offset allows small signals ($\leq 1\text{ mV}$), that exist on top of a DC supply, to be centered on an oscilloscope screen for maximum vertical sensitivity.
- Low DC loading due to a 50 k Ω input impedance at DC.
- Large $\pm 850\text{ mV}$ active signal range in addition to the offset range

CAUTION

Before using the probe, refer to "[Safety Information](#)" on page 18. Handle the probe with care and refer to the safety notices in this manual. Avoid any mechanical shocks to this product in order to guarantee accurate performance and protection.

1 General Information

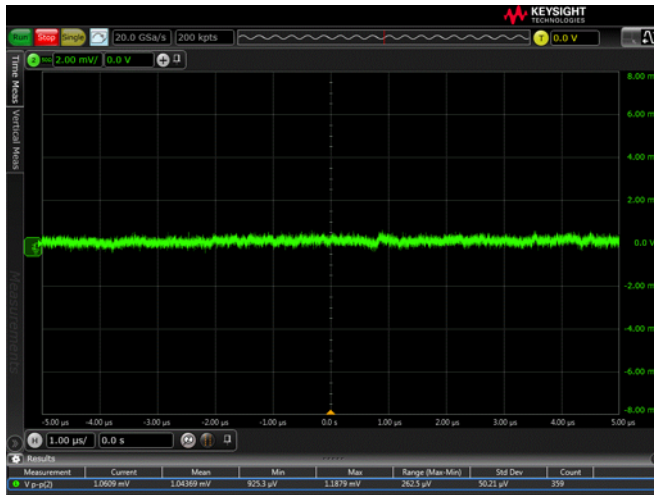

Figure 1 Example of Measured Mean Noise at 2 GHz BW: 1.04369 mV_{p-p}

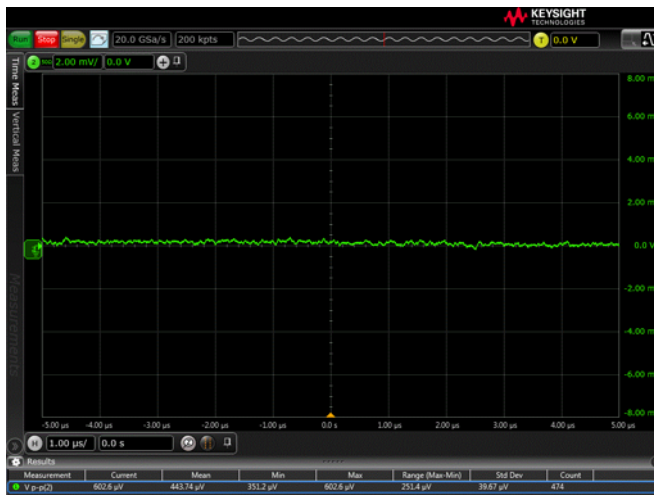

Figure 2 Example of Measured Mean Noise at 20 MHz BW: 443.74 μV_{p-p}

Oscilloscope Compatibility

The N7020A probe is compatible with the Keysight oscilloscopes shown in [Table 1](#). The table also lists the minimum required firmware version for the oscilloscopes.

NOTE

The N7020A probe is designed for oscilloscopes with 50Ω AutoProbe-interface channel inputs. The AutoProbe interface provides the power to the probe.

Table 1 Compatible Oscilloscopes and Support

Infiniium Oscilloscopes	Required Firmware Version
S-Series	≥ 5.20
9000A	≥ 5.20
4000 X-Series	≥ 4.00
3000T X-Series	≥ 4.00

Is Your Oscilloscope Software Up-to-Date? Keysight periodically releases software updates to support your probe, fix known defects, and incorporate product enhancements. To download the latest firmware, go to www.keysight.com and search for your oscilloscope's topic. Click on the "Drivers, Firmware & Software" tab.

Accessories

Supplied Accessories

The probe comes with the accessories shown in [Figure 3](#).

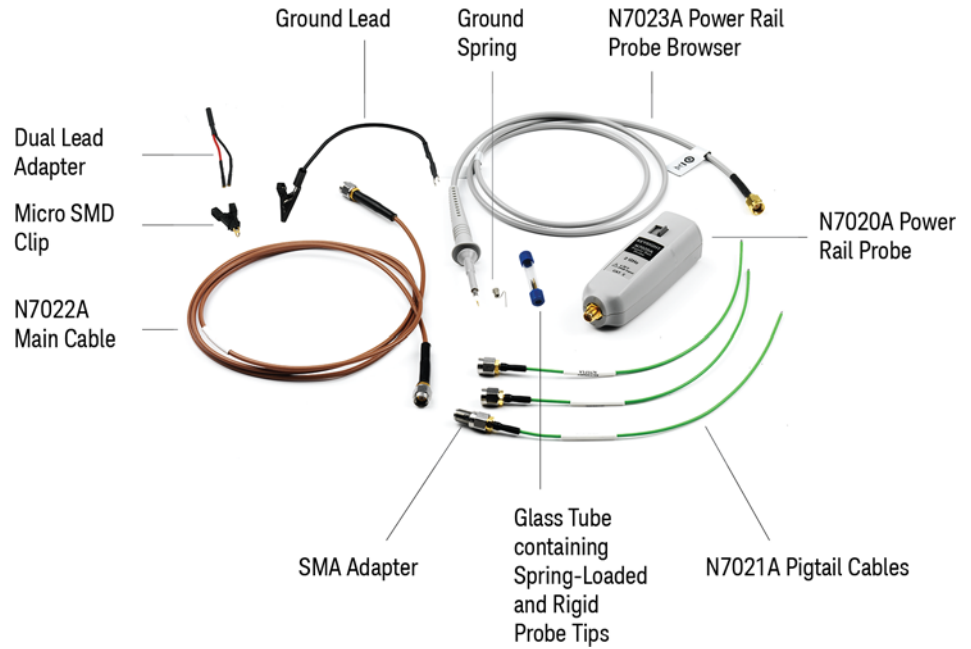

Figure 3 Probe with Accessories

Table 2 Supplied Accessories

Accessories	Quantity
N7021A Pigtail Cables	3
SMA Adapter*	1
N7022A Main Cable	1
N7023A Power Rail Probe Browser, with accessories	1
Ground spring 2.5 mm	1
Ground lead 15 cm	1
Spring-loaded probe tips	3 (One spring-loaded tip is pre-installed by Keysight into the N7023A browser.)
Rigid probe tips	2
Dual lead adapter	1
Micro SMD clip†	1
Protection cap 2.5 mm‡	1
Color coding rings‡	3x4 colors

* Connects the main cable to the Pigtail Cables

† Also called as Surface Mount Grabber

‡ Not shown in figure

N7023A Power Rail Probe Browser

The N7023A power rail probe browser helps in probing the power rails conveniently. Mechanically, this browser is similar to a traditional passive probe and is used in the same manner. The trade-off for this convenience is the lower signal fidelity than the coaxial N7021A pigtail cables or the coaxial N7022A main cable.

To use this browser, replace the N7022A main cable attached to the N7020A power rail probe with the N7023A power rail probe browser as shown in the figure below.



2.5 mm Ground Spring The ground spring provides the highest performance connection for the N7023A power rail probe browser.



15 cm Ground Lead This ground lead can be used to reach grounding locations that are farther away from the probing location than can be reached by the ground spring. However, the longer lead means it has a larger inductance in the ground return path which corresponds to a lower performance than using the ground spring.

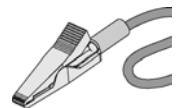

Dual Lead Adapter The dual lead adapter allows you to easily connect the N7023A power rail probe browser to popular 0.1" pin headers with 0.025" square pins. This dual lead adapter has no shorting hazards since all external metal surfaces are insulated.



Dual Lead Adapter with Micro SMD Clip The Micro SMD clips are specially designed to provide fast and convenient hands-free probing of surface mount capacitors. The Micro SMD clip is used in conjunction with the dual lead adapter. It is a best practice to twist the leads of the dual lead adapter to reduce coupling of external noise into the probe.



Channel Identification rings The channel identification rings can be used to keep track of which probe is connected to which channel input on your oscilloscope. Place one ring on the probe cable near the oscilloscope input and place another ring of the same color near the probe head. This ensures that you can pick up a probe and immediately know which channel it is connected to without having to track the cable back to the oscilloscope channel input.



Replacing Rigid, Solid Power Rail Probe Browser Tip, and Spring-Loaded Power Rail Probe Browser Tips

The solid tips and spring-loaded tips are replaceable. Spring loaded power rail probe browser tips offer a method of probing signals that is less susceptible to vibration or movement than traditional rigid tips. Many users find it easier to use this type of tip. The spring loaded tips work when they are either partially or fully compressed and are protected against over compression damage.

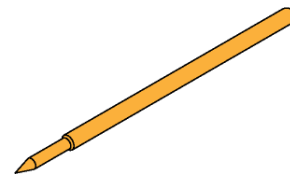

To change the N7023A power rail probe browser tip, use pliers to grip the tip and pull it straight out of its contact socket along the axis of the N7023A power rail probe browser. Do not grip the plastic insulator or the housing with the pliers because the tip could be crushed (see Figure 4). This could result in being unable to remove the tip and/or damaging the



N7023A power rail probe browser. Once the N7023A power rail probe browser tip is removed, the new tip can be inserted with pliers into the contact socket along the axis of the N7023A power rail probe browser. In order to insert the N7023A power rail probe browser tip completely into the housing, carefully press the browser tip against a hard surface.

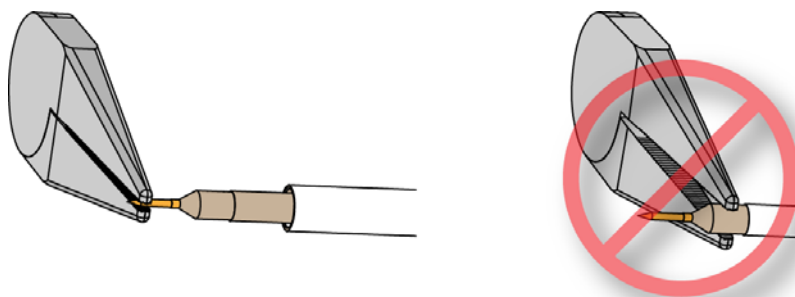

Figure 4 Proper Tip Removal Technique

WARNING

You should exercise caution when using these sharp browser tips to avoid personal injury.

Orderable Accessories

The orderable parts shown in this picture are listed in [Table 3](#) on page 14.

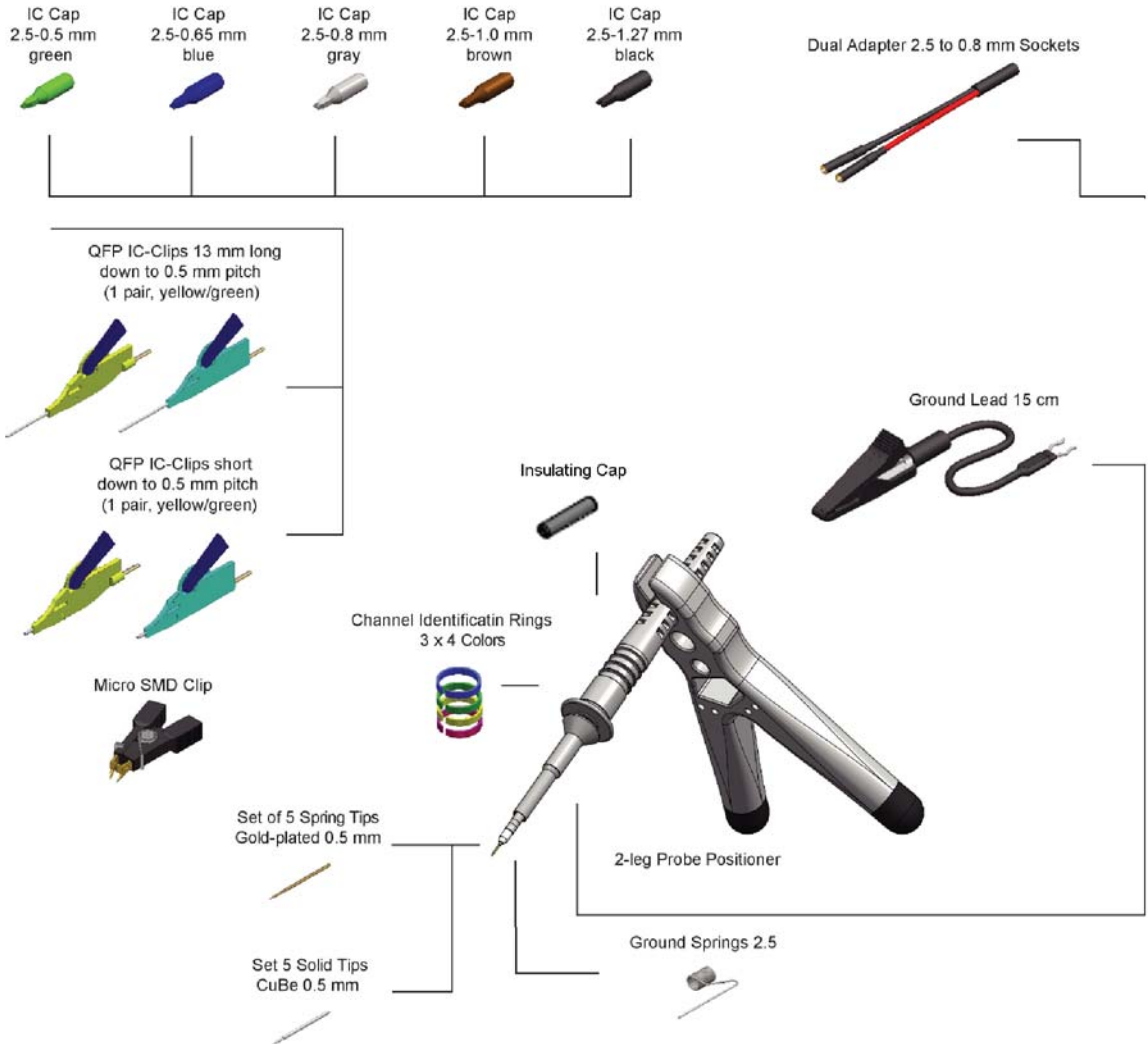

Table 3 Orderable Parts Quantity

Optional Accessory	Quantity	Accessory P/N	Keysight Product Number
IC Cap 2.5 - 0.5 mm green	3	0960-2983	-
IC Cap 2.5 - 0.65 mm blue	3	0960-2984	-
IC Cap 2.5 - 0.8 mm gray	3	0960-2988	-
IC Cap 2.5 - 1.0 mm brown	3	0960-2989	-
IC Cap 2.5 - 1.27 mm black	3	0960-2986	-
Insulating Cap 2.5 mm	1	0960-2985	-
Ground Spring 2.5 mm	3	0960-2980	N4838A
Set of 5 Spring Tips Gold-plated 0.5 mm	1	0960-2981	-
Set of 5 Solid tips CuBe 0.5 mm	1	0960-2979	-
Dual adapter 2.5 to 0.8 mm sockets	1	0960-2898	N4836A
QFP IC-Clips 13 mm long down to 0.5 mm pitch (1 pair yellow/green)	2	0960-2992	-
QFP IC-Clips short down to 0.5 mm pitch (1 pair yellow/green)	2	0960-2995	-
Ground Lead 15 cm	1	0960-2906	N4837A
2-leg Probe Positioner	1	N2786-60001	N2786A
Micro SMD Clip	1	1400-3652	-

Inspecting the Probe

- Inspect the shipping container for damage.

Keep the damaged shipping container or cushioning material until the contents of the shipment have been checked for completeness and the probe has been checked mechanically and electrically.

- Check the accessories.
- If the contents are incomplete or damaged, notify your Keysight Technologies Sales Office.
- Inspect the probe. If there is mechanical damage or defect, or if the probe does not operate properly or pass calibration tests, notify your Keysight Technologies Sales Office.

If the shipping container is damaged, or the cushioning materials show signs of stress, notify the carrier as well as your Keysight Technologies Sales Office. Keep the shipping materials for the carrier's inspection. The Keysight Technologies office will arrange for repair or replacement at Keysight Technologies' option without waiting for claim settlement.

WARNING

Must be Grounded. Before making connections to the input leads of this probe, ensure that the probe's output connector is attached to the channel input of the oscilloscope and the oscilloscope is properly grounded.

CAUTION

To protect against electrical shock, use only the accessories supplied with this probe or in the accessory kit.

Handling the Probe

Handle the probe with care to avoid injury, especially when it is fitted with the extra thin and sharp spring contact tip.

CAUTION

The browser cable is a sensitive part of the N7023A power rail probe browser and, therefore, you should be careful not to damage it through excessive bending or pulling. You should also avoid any mechanical shocks to this product in order to guarantee accurate performance and protection.

Cleaning the Probe

Disconnect the N7020A power rail probe from the oscilloscope and clean the probe with a soft cloth dampened with a mild soap and water solution. Make sure that the probe is completely dry before reconnecting it to an oscilloscope. Avoid using abrasive cleaners and chemicals containing benzene or similar solvents.

Safety Information



This manual provides information and warnings essential for operating this probe in a safe manner and for maintaining it in safe operating condition. Before using this equipment and to ensure safe operation and to obtain maximum performance from the probe, carefully read and observe the following warnings, cautions, and notes.

This product has been designed and tested in accordance with accepted industry standards, and has been supplied in a safe condition. The documentation contains information and warnings that must be followed by the user to ensure safe operation and to maintain the product in a safe condition.

Note the external markings on the probe that are described in this document.

WARNING

To avoid personal injury and to prevent fire or damage to this product or products connected to it, review and comply with the following safety precautions. Be aware that if you use this probe assembly in a manner not specified, the protection this product provides may be impaired.

WARNING

Use Only Grounded Instruments.

Do not connect the probe's ground lead to a potential other than earth ground. Always make sure the probe and the oscilloscope are grounded properly.

WARNING

Connect and Disconnect Properly.

Connect the probe to the oscilloscope and connect the ground lead to earth ground before connecting the probe to the circuit under test. Disconnect the probe input and the probe ground lead from the circuit under test before disconnecting the probe from the oscilloscope.

WARNING

Do Not Operate Without Covers. To avoid electrical shock or fire hazard, do not operate this probe with the covers removed.

WARNING

Do Not Operate in Wet / Damp Conditions.

To avoid electrical shock, do not operate this probe in wet or damp conditions.

WARNING

Do Not Operate in an Explosive Atmosphere.

To avoid injury or fire hazard, do not operate this probe in an explosive atmosphere.

WARNING

Avoid Exposed Circuit. To avoid injury, remove jewelry such as rings, watches, and other metallic objects. Do not touch exposed connections and components when power is present.

WARNING

For Indoor Use Only. Only use this probe indoors.

WARNING

Do Not Operate With Suspected Failures. If you suspect there is damage to this probe, have it inspected by a qualified service personnel.

Concerning the Oscilloscope or Voltage Measuring Instrument to Which the Probe is Connected

WARNING

Whenever it is likely that the ground protection is impaired, you must make the instrument inoperative and secure it against any unintended operation.

WARNING

If you energize the instrument by an auto transformer (for voltage reduction or mains isolation), the ground pin of the input connector terminal must be connected to the earth terminal of the power source.

WARNING

Before turning on the instrument, you must connect the protective earth terminal of the instrument to the protective conductor of the (mains) power cord. The mains plug shall only be inserted in a socket outlet provided with a protective earth contact. You must not negate the protective action by using an extension cord (power cable) without a protective conductor (grounding). Grounding one conductor of a two-conductor outlet is not sufficient protection.

WARNING

Only fuses with the required rated current, voltage, and specified type (normal blow, time delay, etc.) should be used. Do not use repaired fuses or short-circuited fuse holders. To do so could cause a shock or fire hazard.

WARNING

Capacitors inside the instrument may retain a charge even if the instrument is disconnected from its source of supply.

Returning the Probe for Service

If the probe is found to be defective we recommend sending it to an authorized service center for all repair and calibration needs. Perform the following steps before shipping the probe back to Keysight Technologies for service.

- 1** Contact your nearest Keysight sales office for information on obtaining an RMA number and return address.
- 2** Write the following information on a tag and attach it to the malfunctioning equipment.
 - Name and address of owner
 - Product model number (for example, N7020A)
 - Product Serial Number (for example, MYXXXXXXXX)
 - Description of failure or service required.

NOTE

Include probing and browsing heads if you feel the probe is not meeting performance specifications or a yearly calibration is requested.

- 3** Protect the probe by wrapping in plastic or heavy paper.
- 4** Pack the probe in the original carrying case or if not available use bubble wrap or packing peanuts.
- 5** Place securely in sealed shipping container and mark container as "FRAGILE".

NOTE

If any correspondence is required, refer to the product by serial number and model number.

Contacting Keysight Technologies

For technical assistance, contact your local Keysight Call Center.

- In the Americas, call 1 (800) 829-4444
- In other regions, visit <http://www.keysight.com/find/assist>
- Before returning an instrument for service, you must first call the Call Center at 1 (800) 829-4444.

1 General Information

2 Using the N7020A

Requirements for Optimum Probe Performance	24
Low Source Impedance Required	24
Minimize Probe Ground Impedance for the Best Signal Fidelity	25
Common Types of Power Integrity Measurements	27
Connecting to the DUT	29
Avoiding Costly Repairs	31

This chapter explains requirements for using the probe, how to connect the probe to the Device Under Test (DUT), and how to protect the oscilloscope and probe from damage due to ESD.

CAUTION

Always wear an ESD wrist strap when working with active probes. Not doing so can result in damage to the probe and to the oscilloscope's input channel.

NOTE

If the N7020A input is connected to an S-series oscilloscope at vertical settings at or below 20 mV/div with more than 200 mV of applied offset with no signal on the probe input, the probe output may be indeterminate. Upon zeroing the offset, increasing the vertical setting, or connecting the probe input to a low impedance (power rail), the output will be correctly restored.

Requirements for Optimum Probe Performance

Low Source Impedance Required

The N7020A is designed explicitly for measuring DC power supplies. In order to maintain a flat frequency response across the probe's bandwidth, the DUT must have extremely low source impedance, like that of a power rail. The N7020A has a non-flat input impedance that transitions from $50\text{ k}\Omega$ at DC to 50Ω at 1 MHz and above. Therefore, if the DUT impedance is not low, it will divide with the probe's impedance unequally across frequency, causing a non-flat measurement. The recommended DUT impedance should be much less than 1 ohm. At 1 ohm, the DC-to-AC non-flatness is about 2%. Figure 5 shows the non-flatness for DUT impedances of 0Ω , 1Ω , 25Ω , and 50Ω .

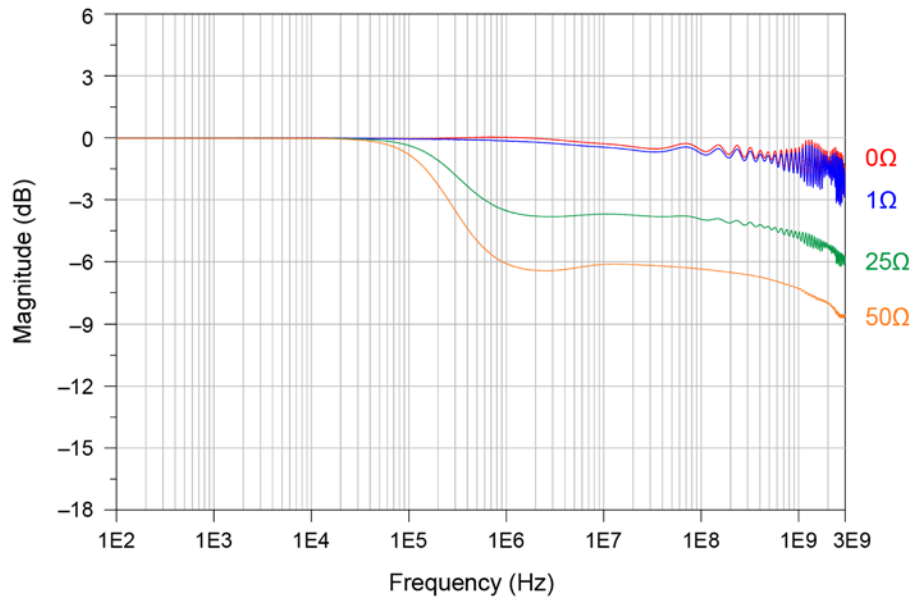

Figure 5 Frequency Response (Probe with N7022A Main Cable) Versus DUT Impedance

To the DC component of a supply voltage, the N7020A probe presents a high impedance and thus low loading (about $50\text{ k}\Omega$). To the AC component of the supply voltage, the probe presents a low 50Ω impedance. This probe's low input impedance, reduces noise on the probe's output to the oscilloscope thus increasing measurement range and accuracy.

The following graph shows the probe's input impedance versus frequency.

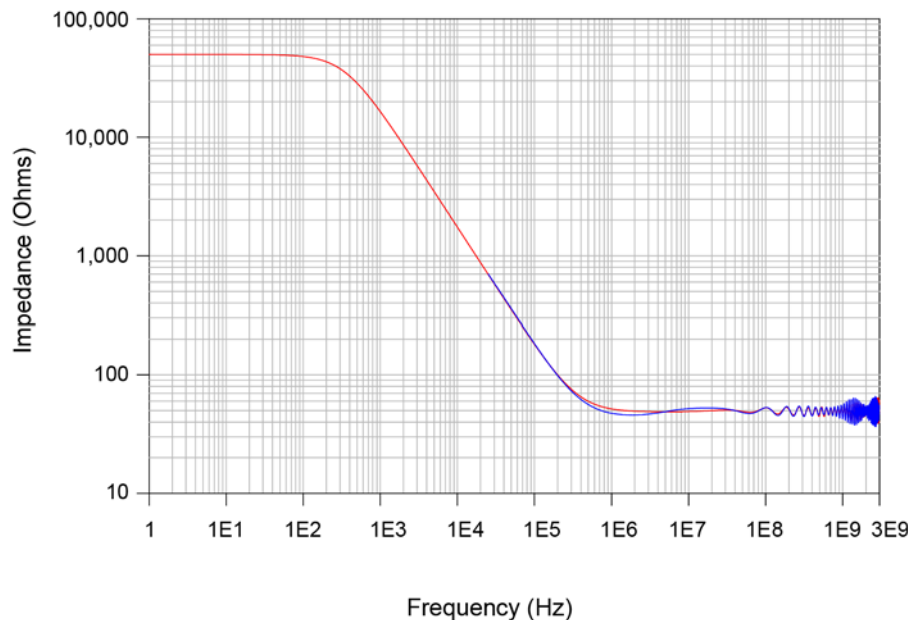

Figure 6 Input Impedance Versus Frequency, Z_{in} Measured, Z_{in} Modeled (N7020A with N7022A Main Cable)

Minimize Probe Ground Impedance for the Best Signal Fidelity

The N7020A is a single-ended probe that is designed for measuring small signals riding on large DC voltages. By using the oscilloscope's offset knob to offset the DC voltage, you can analyze a power rail using maximum vertical sensitivity. With no added noise other than a 10% increase to the oscilloscope channel's noise, due to 1.1:1 attenuation, the N7020A has very low input noise. For example, at maximum sensitivity on an S-series oscilloscope, the input-referred AC_{rms} noise is $140\ \mu V_{rms}$.

To achieve the best signal fidelity, it is vital that the physical connection and ground impedance of the probe be minimized. Any unnecessary length in either the probe's signal or ground can potentially cause capacitive coupling and inductive pick-up larger than the signal of interest. The N7020A provides two connection methods, both well-suited for high fidelity measurements:

- The N7022A main cable, connected directly to an SMA port on the DUT, provides the highest fidelity since the ground and signal are intimately mated with an SMA connector. Connectors other than SMA such as SMB and SMC can be used with an appropriate adapter. The adapters are not supplied with the probe.
- The N7021A is a prepared coaxial-cable pigtail that allows the probe to be soldered to the DUT. It is recommended that the coaxial shield be soldered directly to ground, thus minimizing the ground impedance.

As with any single-ended probe there may be a concern of creating a ground loop by the connection of the DUT ground to the probe/scope ground. This generally does not cause a measurement issue as long as the DUT ground is not radically different than the scope ground. You can test this by connecting the probe's ground and signal contacts to the DUT ground. You should not see any significant signal on the oscilloscope's screen.

NOTE

The N7020A power rail probe also provides a third connection method, using the N7023A power rail probe browser. This browser is connected to the N7020A probe by replacing the N7022A main cable.

Common Types of Power Integrity Measurements

The following list some of the common types of power integrity measurements that you can perform using the N7020A probe:

- Static and dynamic load response.

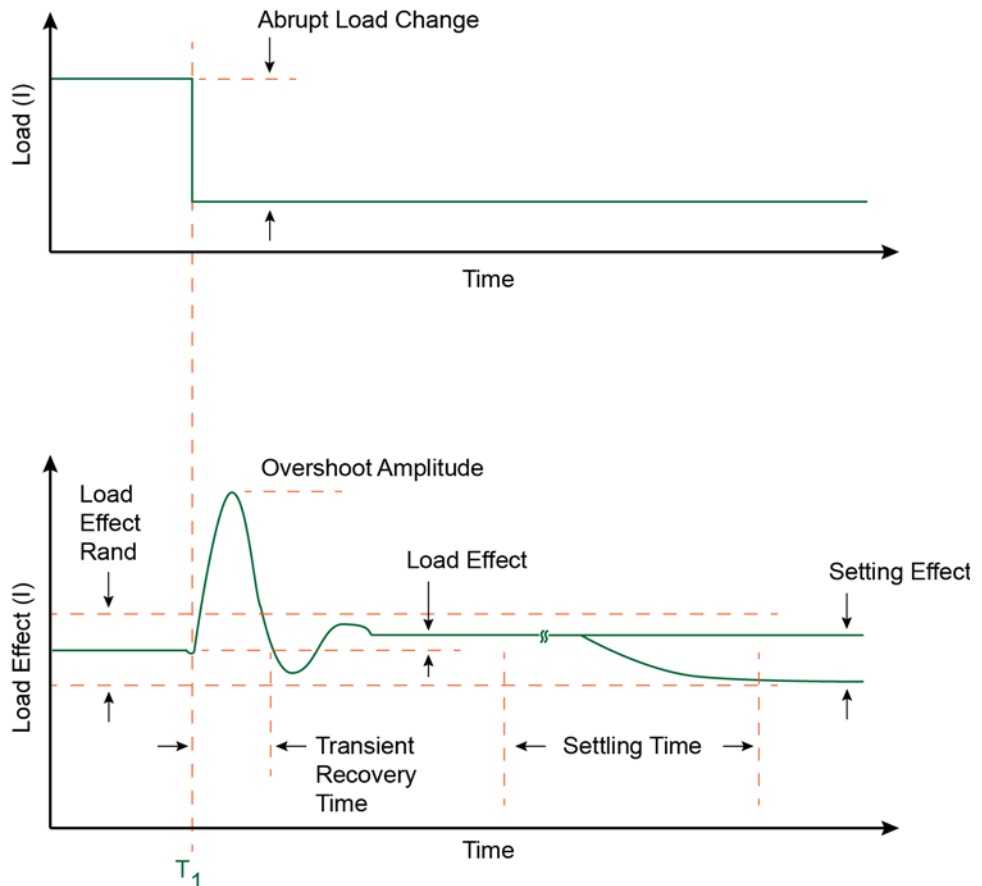

Figure 7 Example of Response to Changing Load

- Supply drift.
- Programmable power rail response.

- High frequency transients and noise.
- PARD (Periodic and Random Disturbances) such as noise, ripple, and switching transients on power rails.

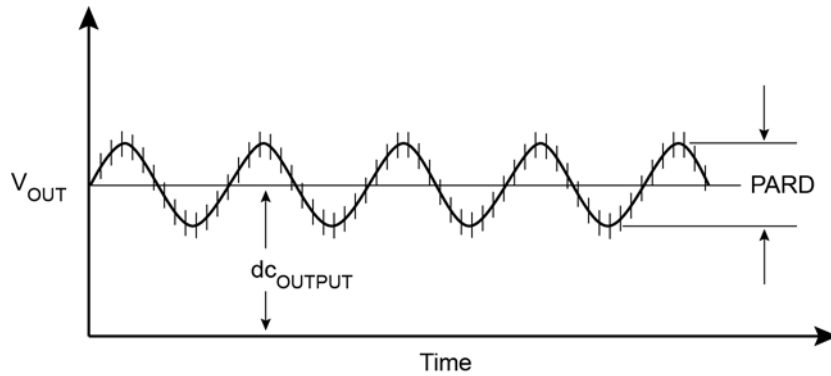

Figure 8 Example of PARD on DC Output

- Product electrical validation at extended temperatures.

Connecting to the DUT

Because supported Keysight S-series and 9000 series oscilloscopes include S-parameter correction for the N7021A and the N7022A cables, always use the following cables combinations for the most accurate measurements:

- N7020A probe with N7022A main cable
- N7020A probe with the N7022A main cable and N7021A pigtail cable. Use the supplied SMA adapter to connect the two cables.
- N7020A probe with the N7023A power rail probe browser (used in the same manner as a traditional passive probe). This browser is connected to the probe by replacing the N7022A main cable.

The N7022A main cable allows you to probe DUTs that are located up to 1.2 meters from the probe. The N7021A pigtail cable is designed to be soldered onto the DUT. [Figure 9](#) on page 30 shows how to solder the end of the N7021A pigtail cable to a DUT. The typical probing point will often be across a bypass capacitor with the cable's outside conductor soldered to ground.

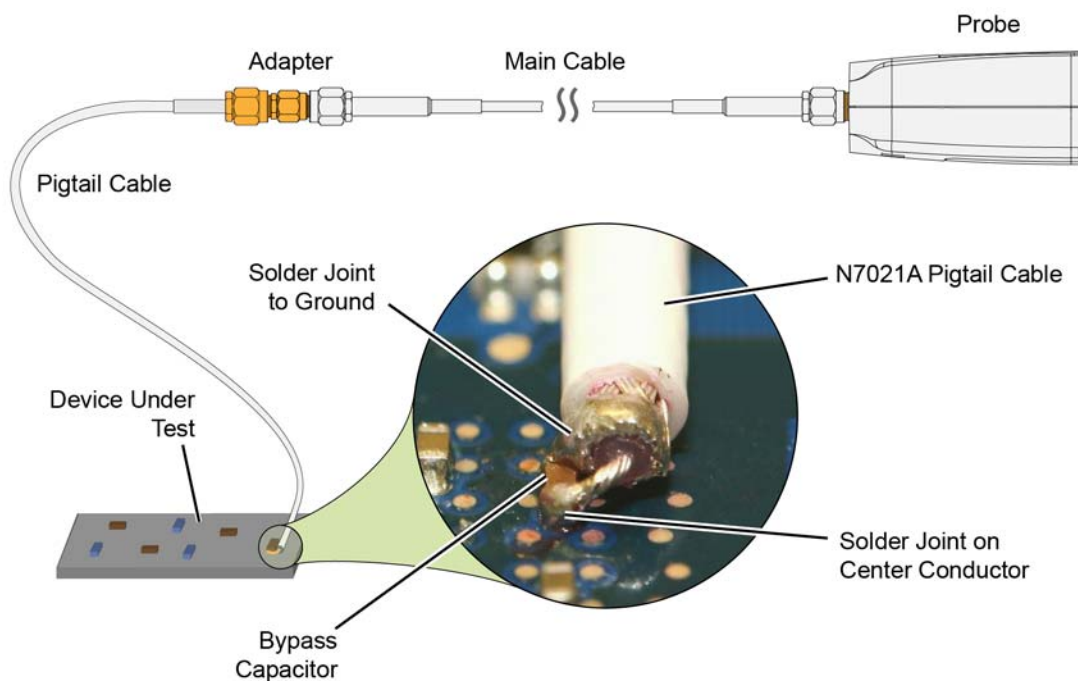

Figure 9 Soldering the Probing End of The N7021A Cable Across a Bypass Capacitor

CAUTION

To avoid accidentally shorting the circuit via the cable's exposed ground, place a small strip of non-conductive tape onto the board before attaching the coax. To avoid undue stress to the solder joints, tape the cable to the DUT.

Avoiding Costly Repairs

When connecting or using the probe, use caution to avoid damaging the oscilloscope's channel input circuits due to electrostatic discharge (ESD).

CAUTION

When the probe is connected to the oscilloscope, the oscilloscope's channel input circuits can be damaged by electrostatic discharge (ESD). Avoid applying static discharges to the probe input. Prior to energizing and connecting any accessory cable to the probe, momentarily short the center and outer conductors of the cable together. Be sure that the instrument is properly earth-grounded to prevent buildup of static charge. Wear a wrist-strap or heel-strap.



Figure 10 on page 32 shows an example of a static-safe work station using two types of ESD protection:

- Conductive table-mat and wrist-strap combination.
- Conductive floor-mat and heel-strap combination.

Both types, when used together, provide a significant level of ESD protection. Of the two, only the table-mat and wrist-strap combination provides adequate ESD protection when used alone. To ensure user safety, the static-safe accessories must provide at least 1 M Ω of isolation from ground. Purchase acceptable ESD accessories from your local supplier.

WARNING

These techniques for a static-safe work station should not be used when working on circuitry with a voltage potential greater than 500 volts.

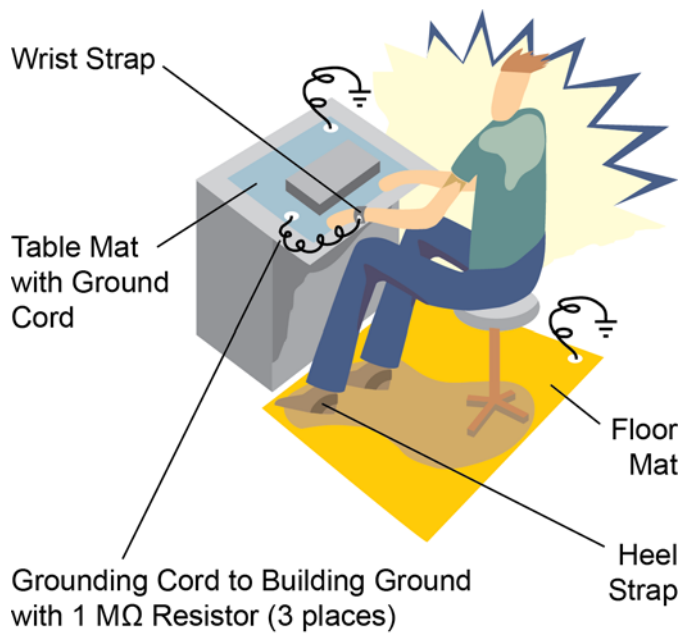

Figure 10 ESD Workstation

3 Calibrating

DC Attenuation/Offset Calibration Using N7022A Main Cable **34**

DC Attenuation/Offset Calibration Using N7023A Power Rail Probe Browser **35**

Skew Calibration (Optional) **36**

Always calibrate the probe before making any critical measurements. A probe calibration removes attenuation errors, offset errors, and timing delays that are introduced by the probe. This chapter contains basic calibration procedures for the supported Infiniium oscilloscopes. For additional information on the probe calibration refer to the oscilloscope's user documentation.

CAUTION

Always wear an ESD wrist strap when working with active probes. Not doing so can result in the probe becoming permanently damaged.

The following calibrations are used:

- DC Attenuation/Offset Calibration Using N7022A Main Cable
- DC Attenuation/Offset Calibration Using N7023A Power Rail Probe Browser
- Skew Calibration (*optional*)

DC Attenuation/Offset Calibration Using N7022A Main Cable

- 1 Turn on the oscilloscope and connect the N7020A probe with the N7022A main cable attached to one of the oscilloscope's input channels.
- 2 Allow the oscilloscope and probe to warm up for 20 minutes.
- 3 If the oscilloscope needs calibration, perform a user calibration before the probe calibration. On the oscilloscope, click Utilities > Calibration.
- 4 Connect the output of the N7022A main cable to the oscilloscope's rear-panel AUX OUT BNC connector as shown in the following picture. You'll need a BNC (m) to SMA (f) adapter.

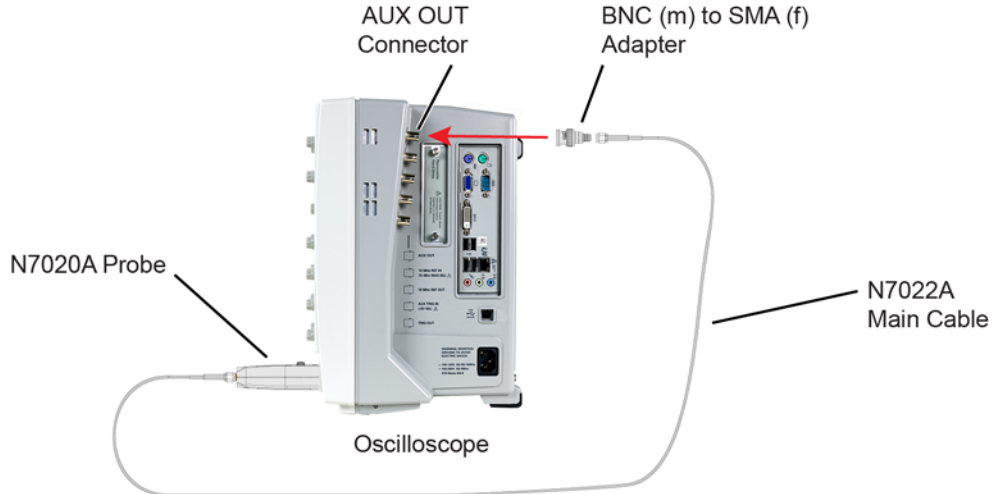

Figure 11 Calibration Setup

- 5 On the oscilloscope, click Setup > Probes.
- 6 In the Probe Calibration dialog box, select the tab representing the channel that has the probe attached.
- 7 In the dialog box, select the type of calibration. Click Start and follow the instructions shown on the oscilloscope.

DC Attenuation/Offset Calibration Using N7023A Power Rail Probe Browser

- 1** Turn on the oscilloscope and connect the N7023A power rail probe browser with the N7020A probe attached to one of the oscilloscope's input channels.
- 2** Allow the oscilloscope and probe to warm up for 20 minutes.
- 3** If the oscilloscope needs calibration, perform a user calibration before the probe calibration. On the oscilloscope, click Utilities > Calibration.
- 4** Connect the ground lugs and the output of the N7023A power rail probe browser to the oscilloscope's front-panel PROBE COMP connector.
- 5** On the oscilloscope, click Setup > Probes.
- 6** In the Probe Calibration dialog box, select the tab representing the channel that has the probe attached.
- 7** In the dialog box, select the type of calibration. Click Start and follow the instructions shown on the oscilloscope.

Skew Calibration (Optional)

The optional skew calibration may be advised when multiple oscilloscope channels are used under the following conditions:

- The default delay applied by the oscilloscope to nominally deskew the probe is not accurate enough for a particular measurement situation, or
- Your test setup has strict timing considerations between channels.

When performing a the skew calibration, an E2655C Performance Verification (PV) and deskew fixture is used. An optional N2787A 3D Probe Positioner or equivalent can be used to hold the probe during the calibration.

NOTE

Before calibrating the probe, verify that the Infiniium oscilloscope has been calibrated recently and that the calibration Δ temperature is within ± 5 °C. If this is not the case, calibrate the oscilloscope before calibrating the probe. This information is found in Infiniium Calibration dialog box.

These calibration procedures require the following parts.

- BNC (male) to SMA (male) adapter
- Deskew fixture
- 50 Ω SMA termination

Procedure Using N7022A Main Cable and N7021A Pigtail Cables

- 1** Connect a BNC (m) to SMA (f) adapter to the E2655C deskew fixture on the connector closest to the yellow pincher.
- 2** Connect the 50 Ω SMA terminator to the connector farthest from the yellow pincher.
- 3** Connect the BNC side of the deskew fixture to the oscilloscope's rear-panel AUX OUT.
- 4** Connect the probe to an oscilloscope channel. The test setup is shown in [Figure 12](#) on page 37,

- 5 Gently hold the pigtail cable's center conductor to the deskew fixture's center conductor. And, hold the pigtail cable's outer conductor to the deskew fixture's ground plane.

CAUTION

To avoid damaging the oscilloscope's AUX OUT connector, do not apply force to the PV fixture. Light probe contact is all that is needed for the calibration.

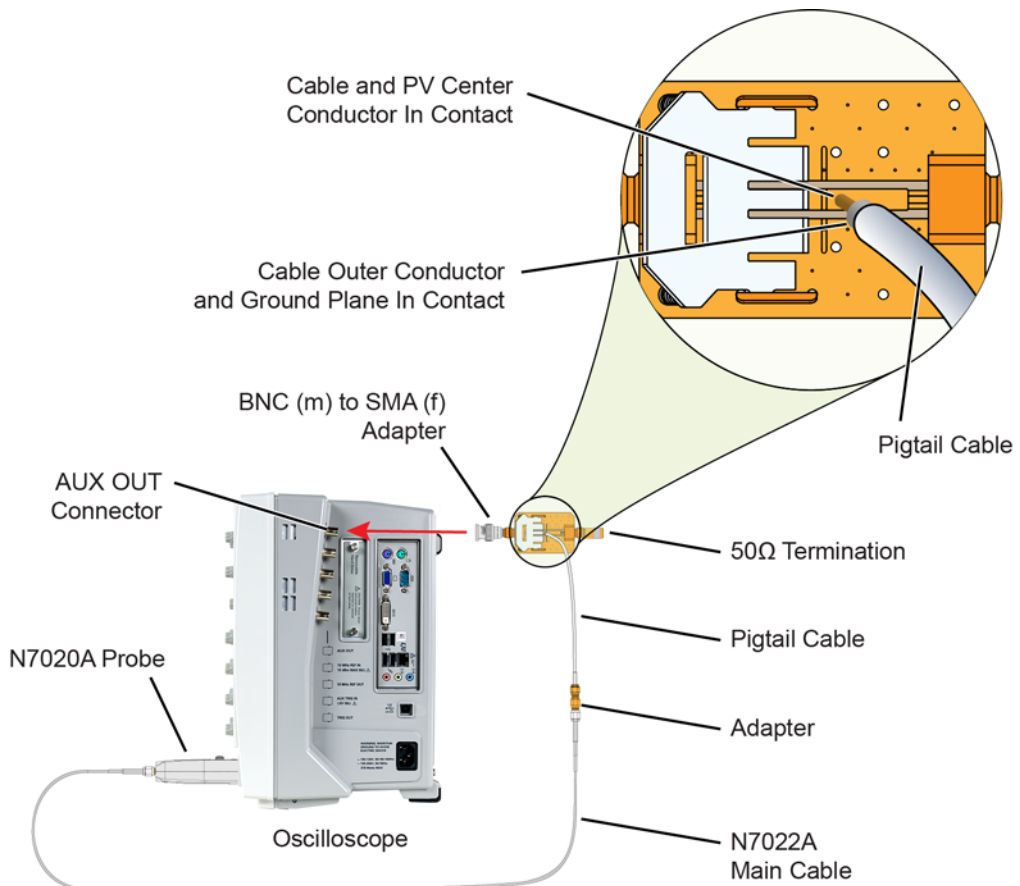

Figure 12 Deskew Setup

CAUTION

NEVER solder a probe tip to the thick-film gold on the deskew fixture. The gold will immediately dissolve into the solder and disappear.

NOTE

You use the N2787A 3D Probe Positioner to hold the pigtail cable in place on the deskew fixture.

NOTE

You can check that the pigtail cable correctly contacts the fixture's center conductor and ground plane by pressing the front-panel auto-scale button. A stable step should be shown on the screen. Pressing auto-scale will close the Probe Calibration dialog box.

- 6** On the Infiniium oscilloscope in the Setup menu, select the channel connected to the probe.
- 7** In the Channel Setup dialog box select the Probes... button.
- 8** In the Probe Setup dialog box select the Calibrate Probe... button.
- 9** In the oscilloscope's Probe Cal dialog box select the Start Skew Calibration... button and follow the on-screen instructions for the skew calibration.

Procedure Using N7023A Power Rail Probe Browser

- 1** Connect a BNC (m) to SMA (f) adapter to the E2655C deskew fixture on the connector closest to the yellow pincher.
- 2** Connect the 50Ω SMA terminator to the connector farthest from the yellow pincher.
- 3** Connect the BNC side of the deskew fixture to the oscilloscope's rear-panel AUX OUT.
- 4** Connect the probe to an oscilloscope channel.

- 5** Probe the deskew fixture's center conductor and ground plane with the N7023A power rail probe browser.
- 6** On the Infiniium oscilloscope in the Setup menu, select the channel connected to the probe.
- 7** In the Channel Setup dialog box select the Probes... button.
- 8** In the Probe Setup dialog box select the Calibrate Probe... button.
- 9** In the oscilloscope's Probe Cal dialog box select the Start Skew Calibration... button and follow the on-screen instructions for the skew calibration.

3 Calibrating

4 Specifications and Characteristics

Specifications and Characteristics 42
Probe Dimensions 44

The tables in this chapter list the specifications for the N7020A probe. Input Impedance DC is the only warranted specification. Connect the probe to a powered-on oscilloscope for at least 20 minutes before any testing to allow the probe to warm up. Ensure that the environmental conditions do not exceed the probe's specified limits.

Specifications and Characteristics

Table 4 N7020A Safety and Regulatory Information



Description	
CEI/IEC 61010-031 CAT II	
	This symbol indicates the Environmental Protection Use Period (EPUP) for the product's toxic substances for the China RoHS requirements.
	The CE mark is a registered trademark of the European Community. ISM GRP 1-A denotes the instrument is an Industrial Scientific and Medical Group 1 Class A product. ICES/NMB-001 indicates product compliance with the Canadian Interference-Causing Equipment Standard.
	This product complies with the WEEE Directive (2002/96/EC) marking requirements. The affixed label indicates that you must not discard this electrical/electronic product in domestic household waste. Product Category: With reference to the equipment types in the WEEE Directive Annex I, this product is classed as a "Monitoring and Control instrumentation" product. Do not dispose in domestic household. To return unwanted products, contact your local Keysight office, or refer to www.keysight.com for more information.

Table 5 Environmental Specifications

Description	Specification (Probe with N7022A Main Cable/N7021A Pigtail Cables)	Specification (Probe with N7023A Power Rail Probe Browser)
Temperature	Operating: -40 °C to +85 °C Non-operating: -30 °C to +70 °C Operating: -10 °C to +55 °C (Probe Pod) Non-operating: -30 °C to +70 °C (Probe Pod)	Operating: -10 °C to +55 °C Non-operating: -30 °C to +70 °C
Altitude	Operating: 3,000 m (9,842 feet) Non-operating: 15,300 m (50,196 feet)	Operating: 3,000 m (9,842 feet) Non-operating: 15,300 m (50,196 feet)
Humidity	Operating: 25 – 85% room humidity Non-operating: 25 – 85% room humidity	Operating: 80% room humidity for temperatures up to 31 °C, decreasing linearly to 40% at 50 °C Non-operating: 95% room humidity for temperatures up to 40 °C
Pollution Degree	Pollution Degree 2	Pollution Degree 2

Table 6 Electrical Characteristics and Specifications

Item	Characteristics (Probe with N7022A Main Cable/N7021A Pigtail Cables)	Characteristics (Probe with N7023A Power Rail Probe Browser)
Probe Bandwidth (~3 dB)	2 GHz	350 MHz (using the included ground spring)
Maximum Input Voltage (non-destructive)	±30V peak input	±30V peak input
Attenuation Ratio	1.1:1	1.1:1
Risetime (calculated, 10–90%)	175 ps	1.0 ns
Offset Range	± 24V	± 24V
Input Impedance at DC*	50 kΩ ±2%	50 kΩ ±2%
Active Signal Range	± 850 mV (about offset voltage)	± 850 mV (about offset voltage)
Probe Noise (at 2 GHz)	10% increase in the noise of the connected Oscilloscope	10% increase in the noise of the connected Oscilloscope
Output Termination	50 Ω scope input	50 Ω scope input
Probe Type	Single Ended	Single Ended

* Warranted specification.

Table 7 Mechanical Characteristics of the N7023A Power Rail Probe Browser

Description	Characteristics
Weight (N7023A Power Rail Probe Browser only)	26 g
Cable length	1 m
Barrel Diameter	2.5 mm

Table 8 Safety Specifications of N7020A Power Rail Probe

Specification
Low Voltage Directive 2006/95/EC
CEI/IEC 61010-031:2008-08

Probe Dimensions

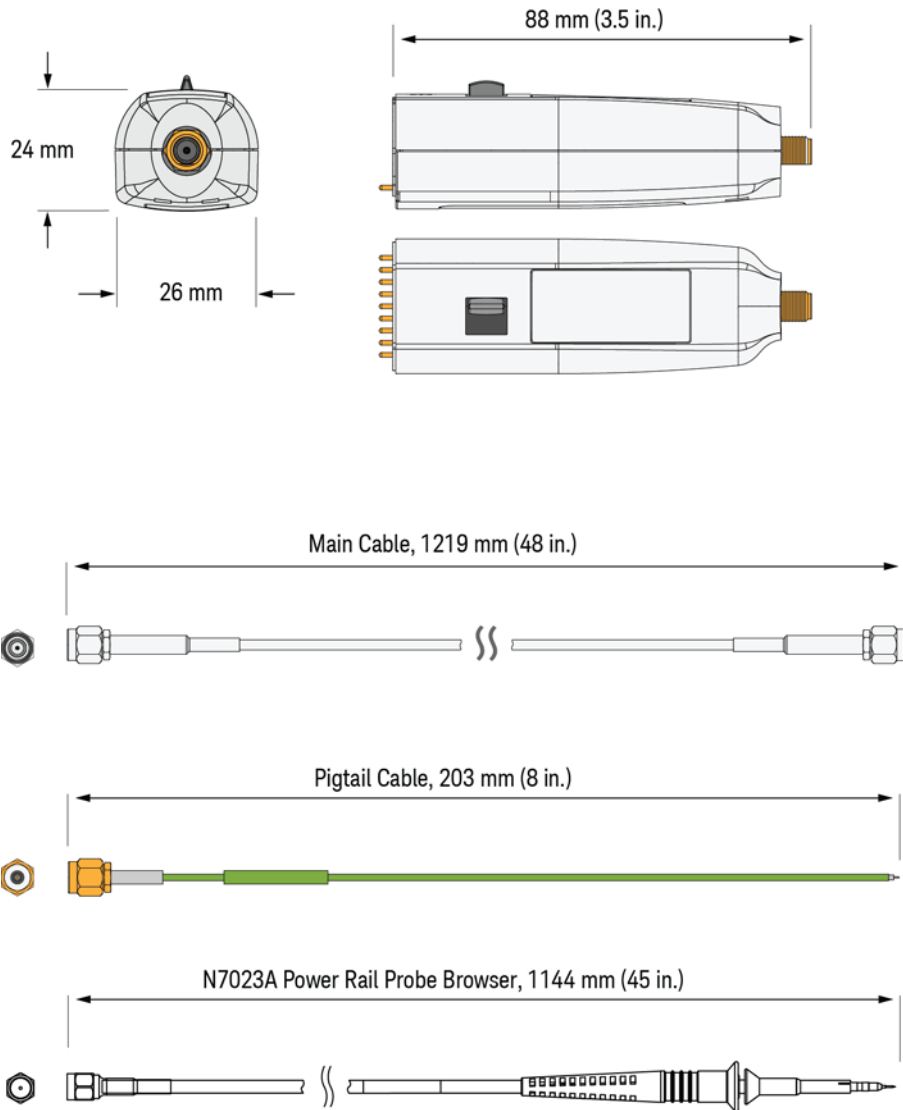

Figure 13 Probe and Accessory Cable Dimensions

5 Performance Plots

N7020A Performance Plots **46**

N7020A Input Impedance Equivalent Model **50**

This chapter includes plots that show the probe's characteristic performance and an input impedance model of the probe. The performance characteristic plots in this chapter are for the N7020A probe with the N7022A main cable attached.

N7020A Performance Plots

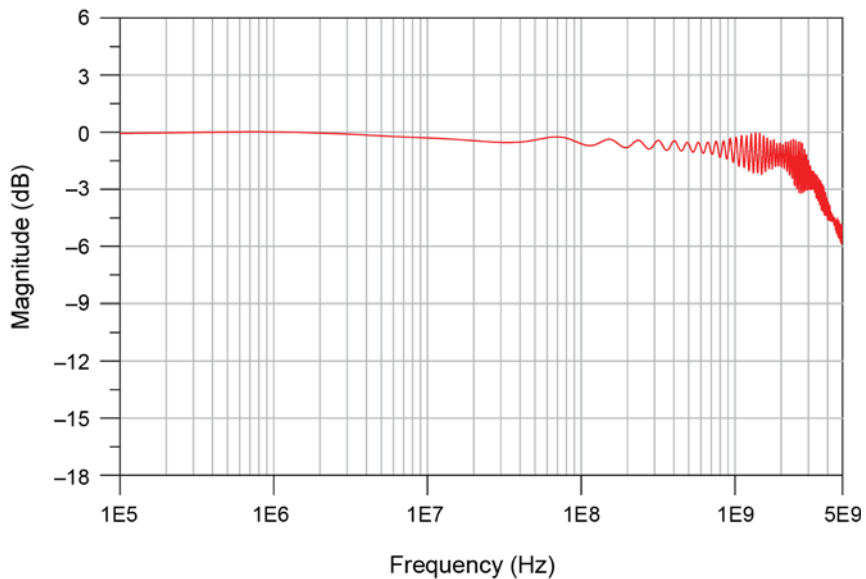

Figure 14 Normalized Frequency Response, V_{out}/V_{in} , 2.5 GHz BW
(N7020A with N7022A Main Cable)

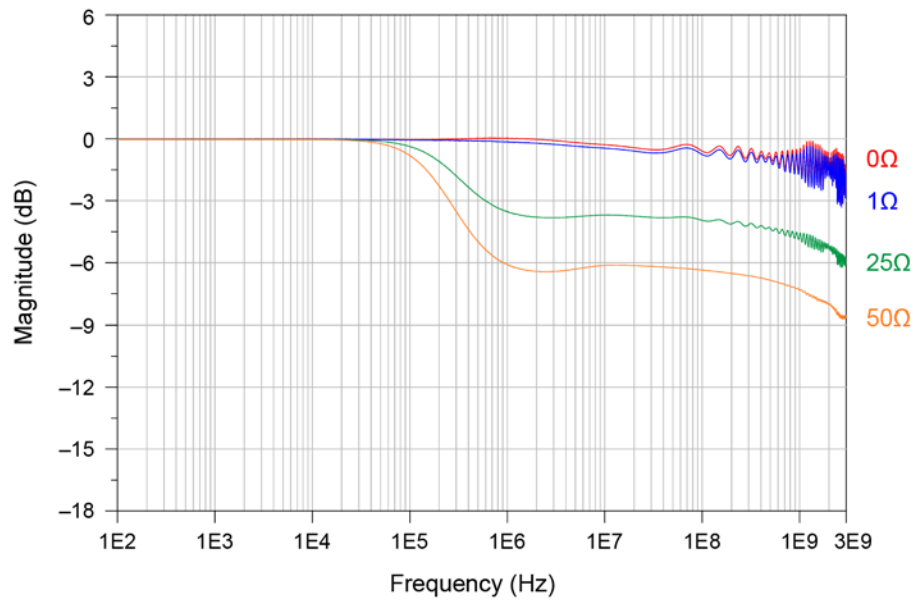
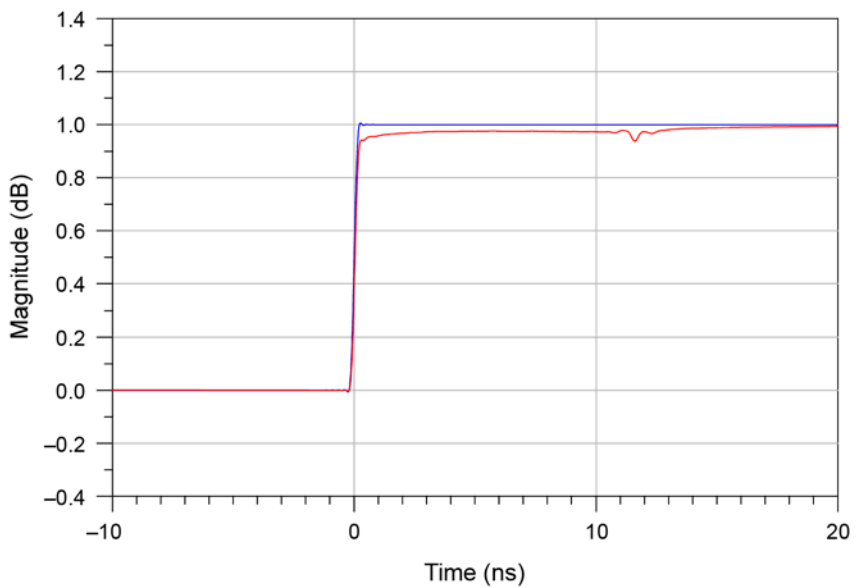

Figure 15 Frequency Response for Different DUT Impedances (N7020A with N7022A Main Cable)



Rise Time, Input Step (10/90%):	250 ps
Rise Time, Input Step (20/80%):	169 ps
Rise Time, N7020A with N7022A (10/90%):	297 ps
Rise Time, N7020A with N7022A (20/80%):	192 ps

Figure 16 Step Tracking (N7020A with N7022A Main Cable)

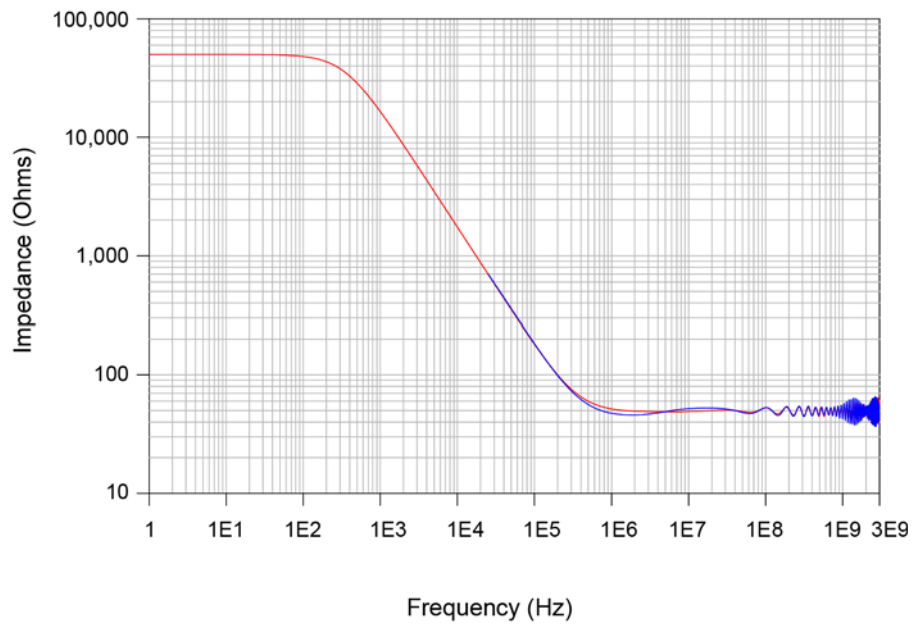

Figure 17 Input Impedance Versus Frequency, Z_{in} Measured, Z_{in} Modeled (N7020A with N7022A Main Cable)

N7020A Input Impedance Equivalent Model

The following Netlist is for the N7020A input impedance equivalent model shown in [Figure 18](#) on page 51.

```
* source N7020A
.EXTERNAL INPUT Vin
.EXTERNAL OUTPUT Vout
R_R3 GND N01679 590
T_T8 N01635 GND N01646 GND Z0=51.7174 TD=177.789ps
T_T4 N01611 GND N01614 GND Z0=50.0323 TD=5.00049ns
T_T9 N01646 GND N01649 GND Z0=56.0807 TD=124.106ps
T_T10 N01649 GND N01652 GND Z0=52.0547 TD=194.457ps
T_T5 N01614 GND N01629 GND Z0=55.4861 TD=14.8781ps
T_T16 N01709 GND VOUT GND Z0=50.4332 TD=1.00771ns
T_T15 N01706 GND N01709 GND Z0=50.9109 TD=173.772ps
C_C1 N01652 N01667 9n
R_R2 N01667 N01670 3.9
T_T11 N01670 GND N01673 GND Z0=47.0657 TD=32.9877ps
T_T12 N01673 GND N01676 GND Z0=48.4028 TD=97.8628ps
T_T14 N01679 GND N01706 GND Z0=51.4414 TD=471.443ps
T_T6 N01629 GND N01632 GND Z0=52.1033 TD=38.7418ps
T_T13 N01676 GND N01679 GND Z0=48.0776 TD=53.1542ps
T_T1 Vin GND N01605 GND Z0=49.0683 TD=148.305ps
R_R4 GND VOUT 50
T_T2 N01605 GND N01608 GND Z0=49.4981 TD=107.256ps
T_T7 N01632 GND N01635 GND Z0=50.8744 TD=76.0454ps
T_T3 N01608 GND N01611 GND Z0=49.4457 TD=277.663ps
R_R1 GND N01635 50k
```

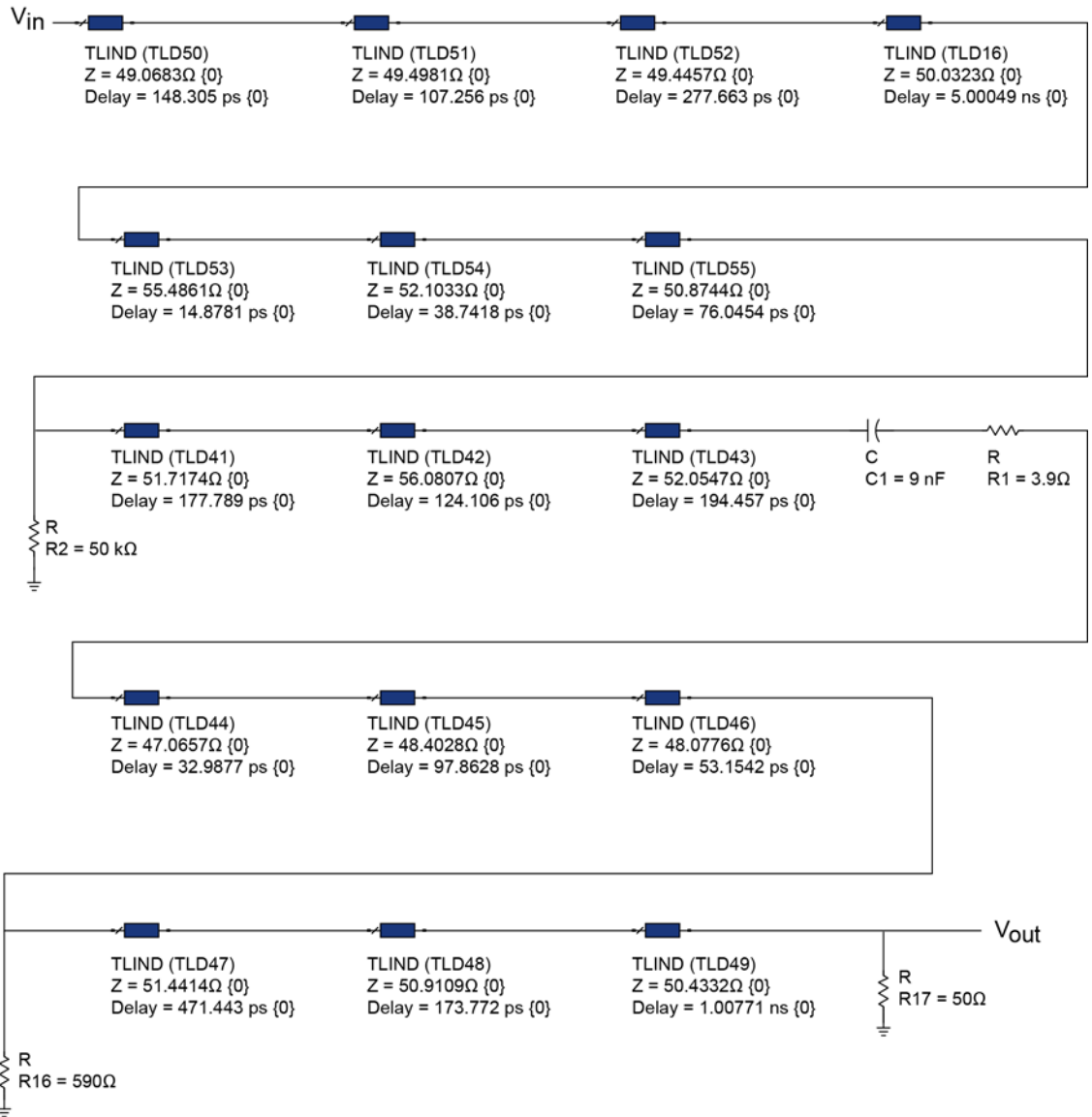

Figure 18 Input Impedance Equivalent Model

6 Performance Verification

Procedure [54](#)

Performance Test Record [55](#)

This chapter tests that the probe meets its specified input resistance, which is $50\text{ k}\Omega \pm 2\%$.

CAUTION

Electrostatic discharge (ESD) can quickly and imperceptibly damage or destroy high performance probes, resulting in costly repairs. Always wear a wrist strap when handling probe components and ensure that cables are discharged before being connected.

NOTE

Allow the probe to warm up for at least 20 minutes.

Table 9 Required Test Equipment

Test Equipment	Critical Specification	Model Number
Oscilloscope	Supported Oscilloscope	S-Series or 9000A series Infiniium Oscilloscope
Digital Multimeter	2 wire resistance accuracy $> \pm 0.01\%$	34401A or equivalent
Adapter	BNC (f) to SMA (m) (In E2655C Kit)	E2655-83201

Procedure

- 1 Connect the equipment as shown in [Figure 19](#).
- 2 Power on the oscilloscope with the oscilloscope application maximized.
- 3 Power on the DMM and select the 2-wire Ohm display on the DMM.

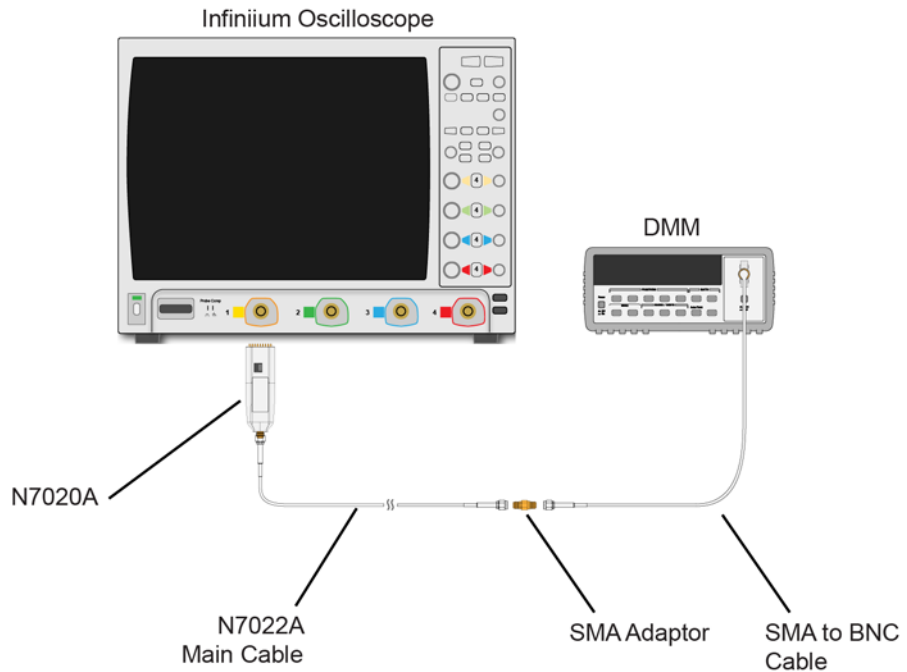

Figure 19 Test Setup

- 4 Read the DMM display for the input resistance.
- 5 Record the result in [Table 10](#) on page 55. To pass this test the result should be between $49\text{ k}\Omega$ and $51\text{ k}\Omega$.

Performance Test Record

Serial #:

Date:

Tested by:

Recommended Next Test Date:

Table 10 Input Impedance Test Results

Test Limits	Result	Pass/Fail
50 k Ω \pm 2%		

Index

Numerics

3D probe positioner, 36

A

accessories, 8
static-safe, 31
altitude, 42

B

bandwidth, 43

C

care, probe, 5
CE mark, 42
characteristics, 41
cleaning, 17
compatible oscilloscopes, 7

E

electrical specifications, 43
environmental specifications, 42

G

grounding probe, 15

H

humidity, 42

I

input resistance, 43
inspecting, 15

K

Keysight Technologies, contacting, 21

M

measurement category, 42
Mechanical Characteristics, 43

O

Orderable Parts, 13
oscilloscope
compatibility, 7

P

performance test record, 55
Power Rail Probe Browser, 10
probe
cable care, 5
cleaning, 17
grounding, 15
inspecting, 15
service, 20
Probe Calibration dialog box, 34
PV fixture, 36

R

repair, 20
resistance testing, 53
returning for service, 20

S

safety, 18
Safety Considerations, 18
safety specifications, 42
safety warnings, 18
service, 20
static-safe accessories, 31

T

temperature, 42
testing
input resistance, 54

W

WEEE Directive, 42

